

### Dual Channel Active EMI & ESD Suppressor for Ethernet Applications

#### Features

- Enables system designers to comply with:
  - ▶ CISPR22 and FCC Part 15, Class B requirements for Radiated and Conducted Emissions
  - ▶ IEC 61000-4-3 requirements for Radiated and Conducted Immunity, Level 3 or higher
  - ▶ IEC 61000-4-2 ESD (Air Discharge) of  $\pm 25\text{kV}$
  - ▶ IEC 61000-4-2 ESD (Contact Discharge) of  $\pm 12\text{kV}$
  - ▶ Cable Discharge Event (CDE) of  $\pm 12\text{kV}$
- Provides up to 10dB of additional common mode noise suppression over the frequency of 1MHz to 125MHz when used with Ethernet magnetics
- Robust built-in ESD suppressors protect the Ethernet PHY and improve system ESD performance
- JESD22-A114, ESD, HBM of  $\pm 8\text{kV}$
- Interfaces to standard Ethernet transformers and 10/100/1000 Ethernet PHYs
- Uses a single standard power rail (3.3V or 2.5V)
- Open drain output stage that can be biased from 1.8V to 3.3V using transformer center-tap supply as needed based on choice of Ethernet PHY.
- Flow-through routing for ease of board layout
- Typical power consumption of 90mW.
- Low power mode available
- Industrial temperature range ( $-40^{\circ}\text{C}$  to  $+85^{\circ}\text{C}$ )

#### Applications

- Ethernet systems requiring additional CM suppression to meet EMC Class B emissions or higher EMI immunity requirements and ESD protection
- PoE and Non-PoE Ethernet systems
- VoIP Phones, IP Cameras, WAPs, Routers, Switches
- Set Top Boxes, Networked Printers and Appliances, Desktop and Laptop Computers

#### Brief Description

The KTA1550 is a single-chip, highly integrated CMOS solution for Common Mode (CM) noise suppression & transient voltage protection in Ethernet applications.

The KTA1550 EMI/ESD Suppressor has been architected and designed to provide system level ESD protection and EMI suppression in Ethernet products, enabling an easier path to system EMC compliance.

The KTA1550 utilizes Kinetic Technologies' patented Active Choke technology which offers superior Common Mode reduction and immunity compared to passive filtering techniques in Ethernet applications. The adaptive and continuous suppression operates over the entire Ethernet signal bandwidth, and it compensates for many variables that are the source of common mode noise in Ethernet systems. It also improves the differential-to-common mode balance of the system. This enables system designers to meet EMI emissions and EMI immunity requirements from the start of the design.

In addition, the KTA1550 includes highly robust ESD/Surge protection diodes to protect the Ethernet PHY from various transient overvoltage events. These are built using Kinetics' proprietary design and layout techniques to safely deal with very high current densities in a CMOS process without creating voltage and/or thermal overstress that causes damage to the device.

Each KTA1550 supports two twisted pair interfaces. 10/100 applications require one KTA1550 device while 10/100/1000 applications require two KTA1550 devices. The KTA1550 is available in a small footprint 16-pin QSOP or 16-pin TDFN 4mm x 2.5mm Reduction of Hazardous Substance (RoHS) compliant package.

#### Ordering Information

Part Number	Marking <sup>1</sup>	Operating Temperature	Package
KTA1550ESQ-TR	LMYWZ	$-40^{\circ}\text{C}$ to $+85^{\circ}\text{C}$	16-Pin QSOP 0.65mm pitch
KTA1550EDS-TR	LMYWZ	$-40^{\circ}\text{C}$ to $+85^{\circ}\text{C}$	16-Pin TDFN 0.5mm pitch

1. "YWZ" is the date code and assembly code.

**Typical Applications**

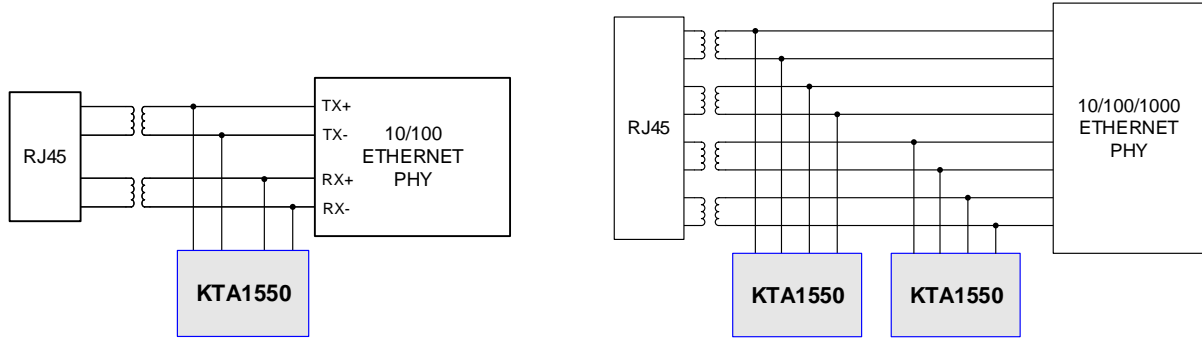

Kinetic Technologies cannot assume responsibility for use of any circuitry other than circuitry entirely embodied in a Kinetic Technologies product. No intellectual property or circuit patent licenses are implied. Kinetic Technologies reserves the right to change the circuitry and specifications without notice at any time.